

New Winstar Enterprise Co., Ltd.

Turbo Blower

SIROCCO®

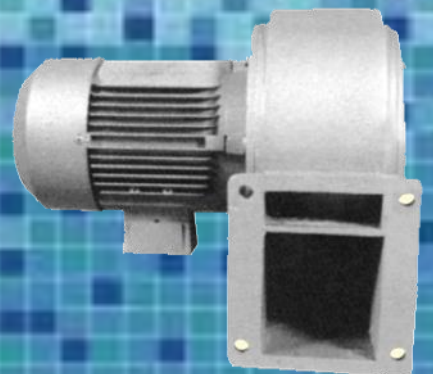
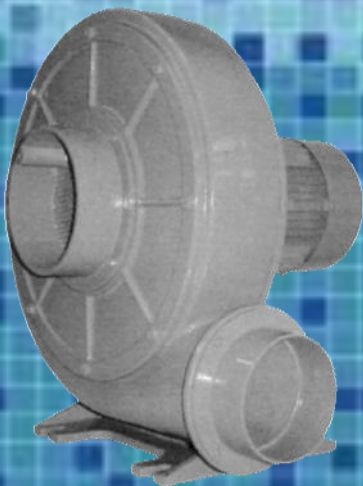

Content

Company Introduction	3
HK Serial.....	4
HK Series.....	5
LK Serial	6
LK Series	7
BCT Serial	8
BCT • LF Series	9
LF Serial.....	10
YF Series.....	11
YF • LT • NT Serial.....	12
NT • LS Series.....	13
LS • BH-BT Serial.....	14
BH-BT Series	15
BH-BT • HN-BT Serial.....	16

Company Introduction

We Have A Profession Technical and Manufacturing Team And Has Been Selling **SIROCCO** Brand Word-Wide.

The Company Has **SIROCCO** Brand More Than Twenty Years Of High-Pressure Blower Field Experience With Spirit Of Providing Quick Service And Technical Based High Quality Products For Our Most Valuable Customers And Potential Business Partners.

Your Interests and Enquires Are Always Welcome.

A Brand New Set Of Modules Have Been Invented To Upgrade Quality Of Our High-Pressure Blowers Leading The New Series Of Blowers Are Both In Appearance, Air Pressure And Volume More Desirable Than The Old Series.

Rigorous Tests And Inspections Have Conducted For Each Blower Ship Out Of The Factory For Firm 100% High Quality Products Deliver To Customers.

ECO AIR® **SIROCCO**®



HK Serial

SIROCCO®

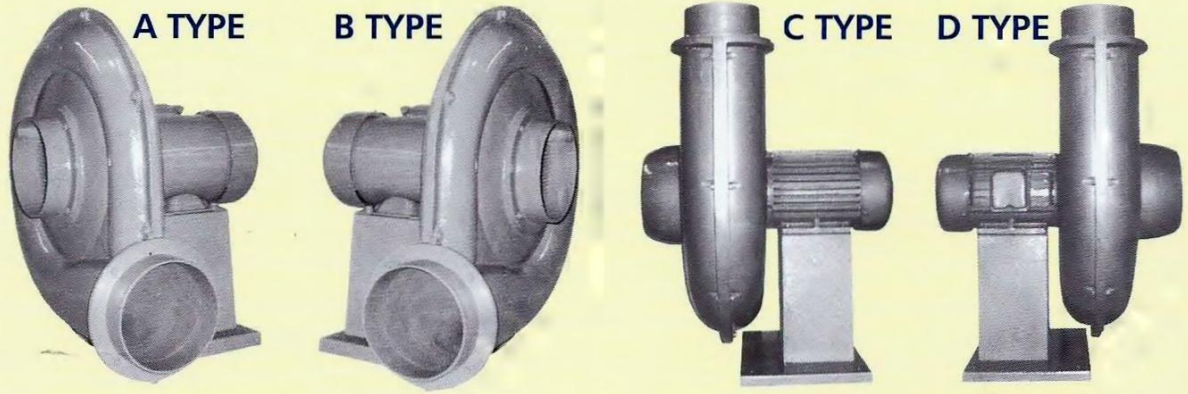

HK-8005 (0.4KW)

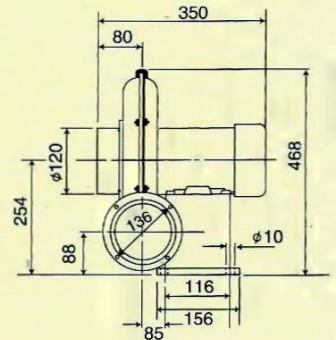
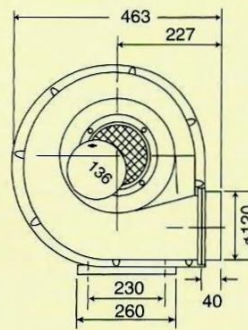
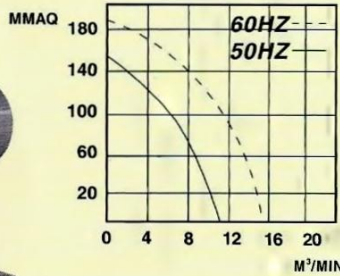

HK-801 (0.75KW)

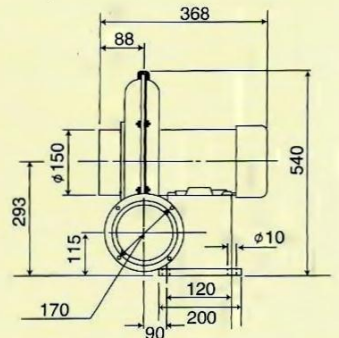
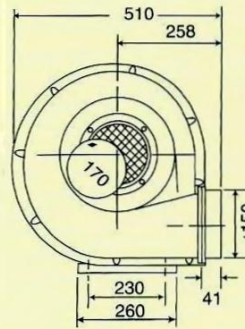
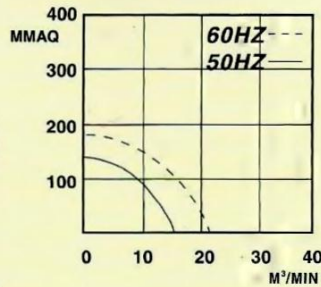

HK-802 (1.5KW)

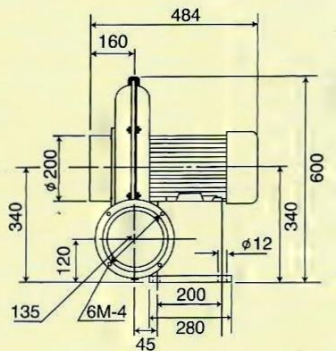
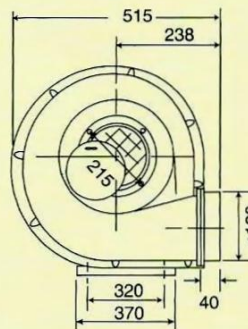
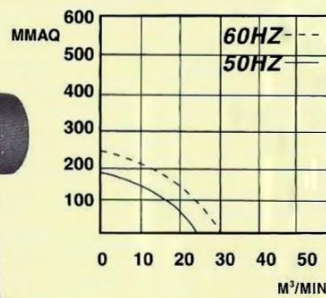

We reserve the right to change the design without notice

HK Series

HK-803 (2.2KW)

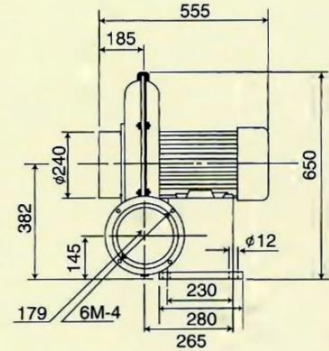
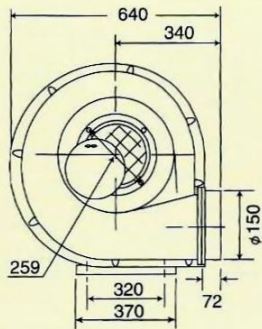
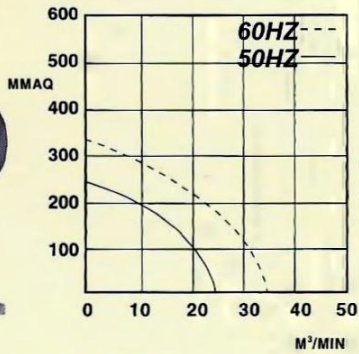

HK-804 (3.7KW)

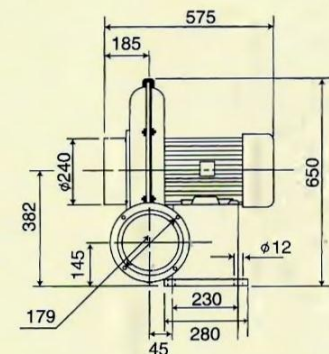
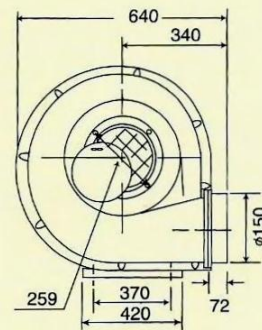
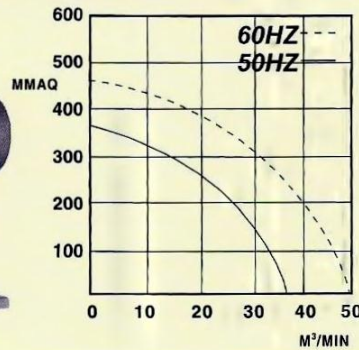

HK-805-810 (5.5-7.5KW)

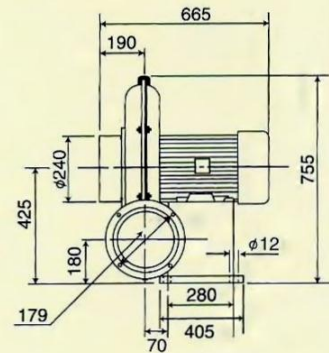
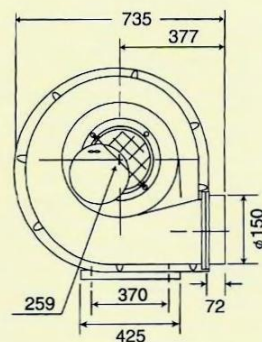
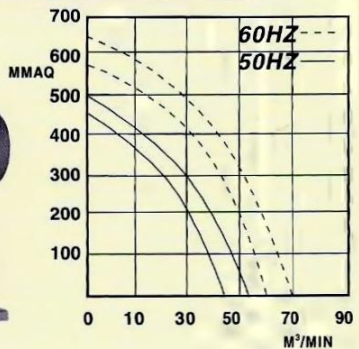

HK-815-820 (11-15KW)

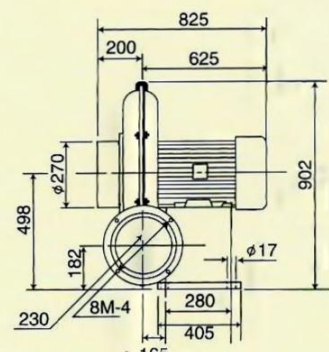
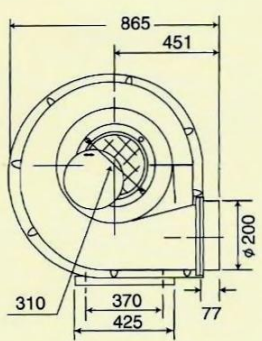
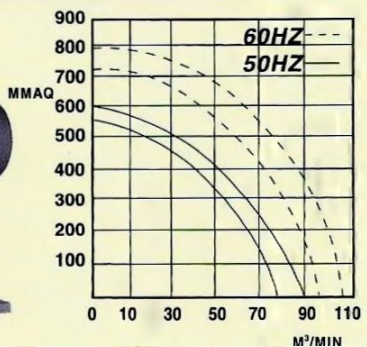

ECO AIR®

We reserve the right to change the design without notice

LK Serial

SIROCCO®

LK-801 (0.75KW)

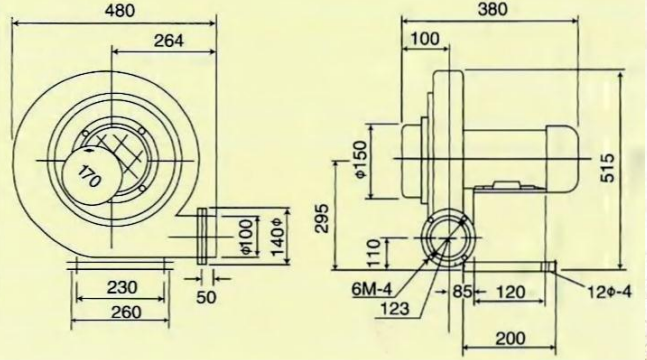
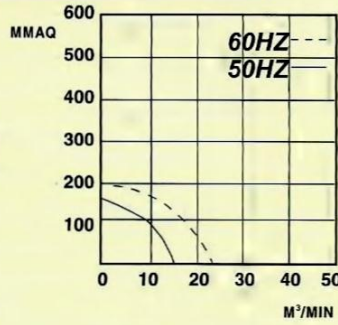

LK-802 (1.5KW)

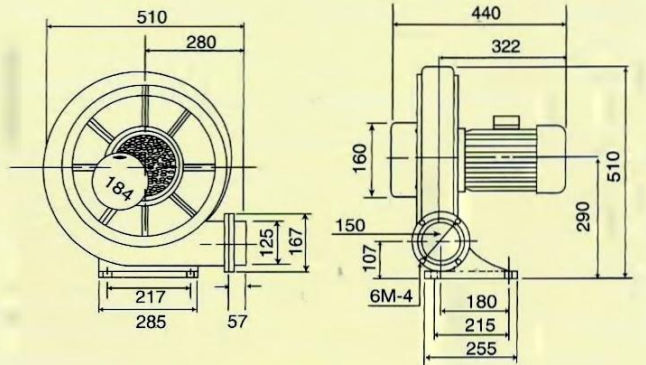
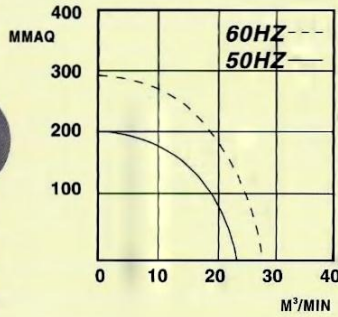

LK-803 (2.2KW)

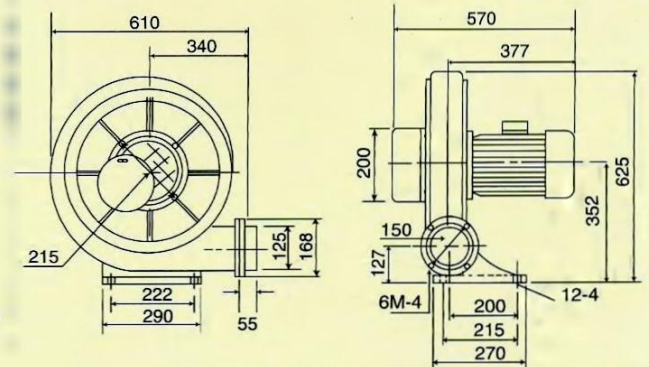
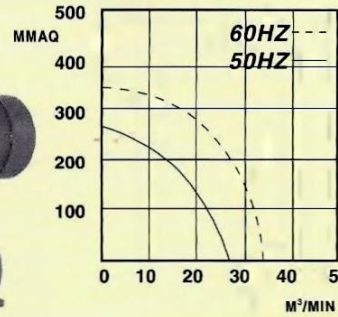

Outlet direction and motor changeable

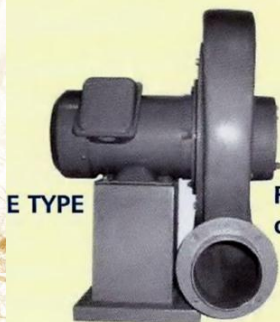

We reserve the right to change the design without notice

LK Series

LK-804 (3.7KW)

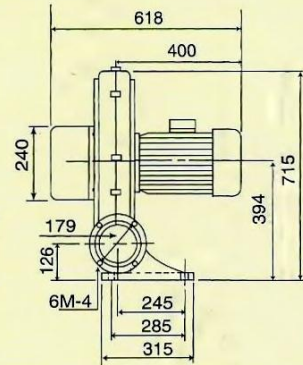
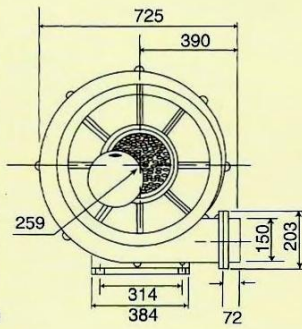
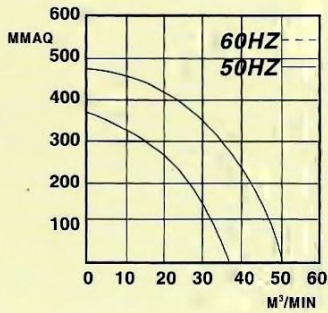

LK-805-810 (5.5-7.5KW)

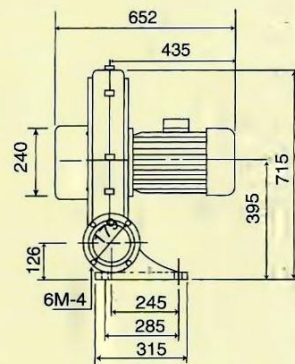
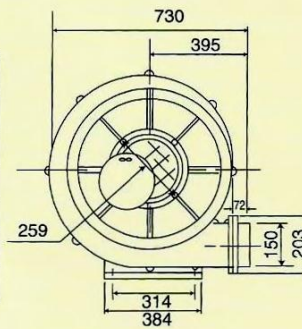
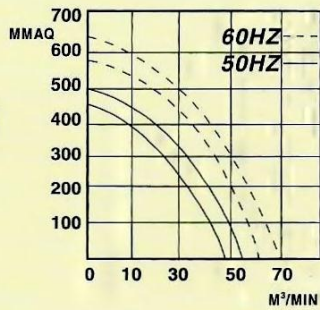
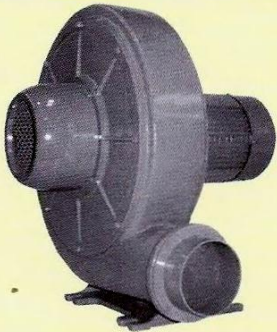

LK-810-L (7.5KW)

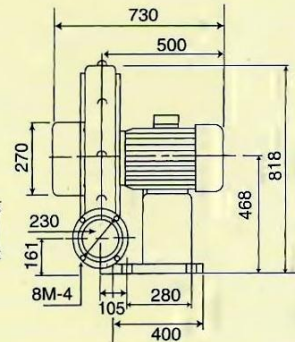
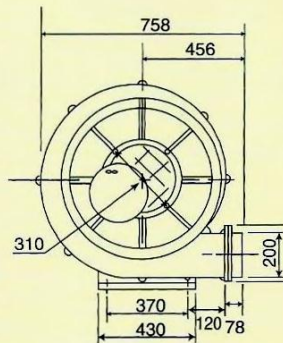
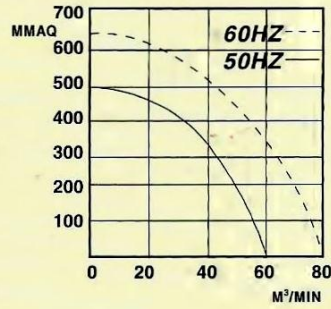

LK-815-820 (11-15KW)

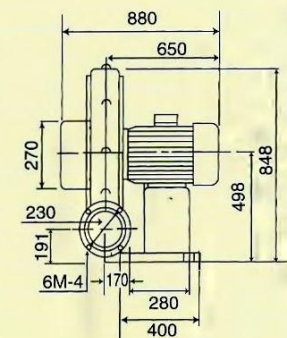
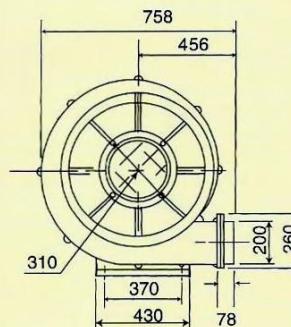
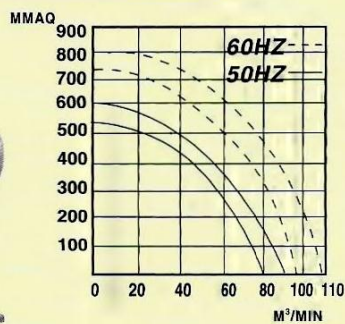
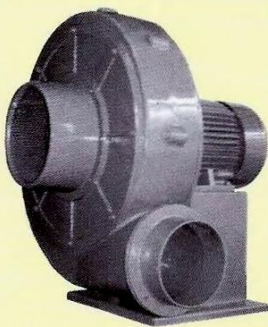

ECO AIR®

We reserve the right to change the design without notice

BCT Serial

SIROCCO®

BCT-060 (0.2KW)

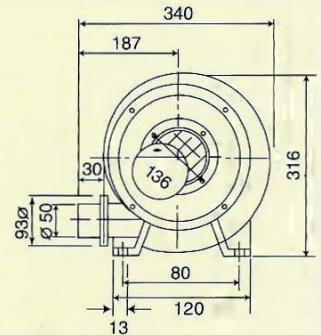
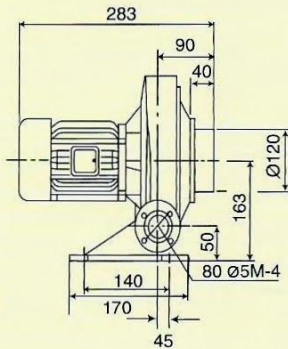
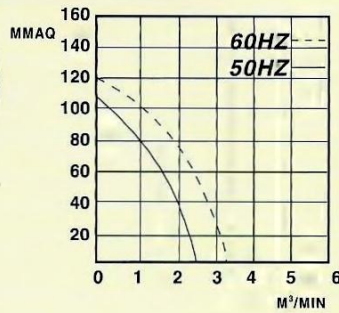

BCT-061 (0.4KW)

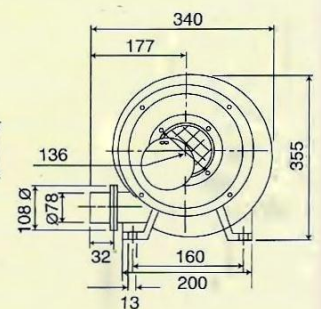
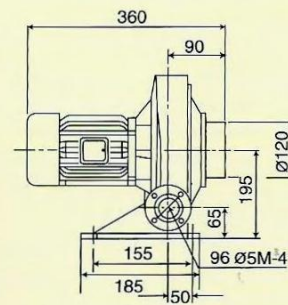
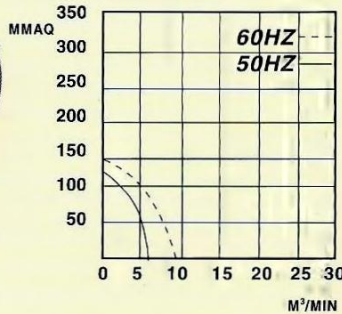

BCT-063 (0.75KW)

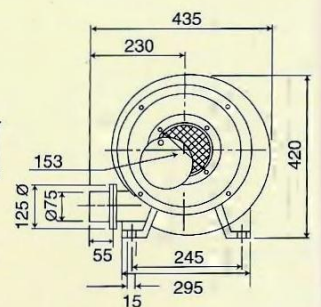
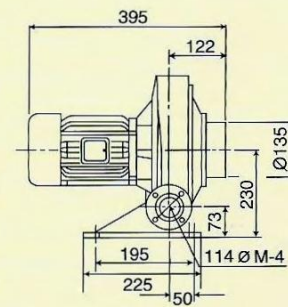
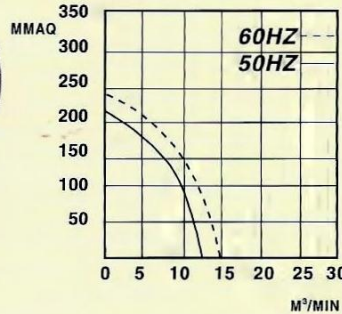

BCT-064 (1.5KW)

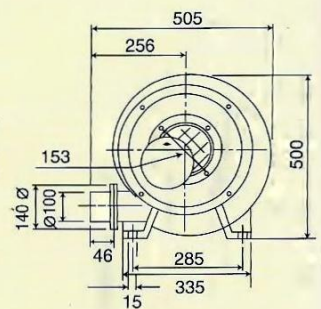
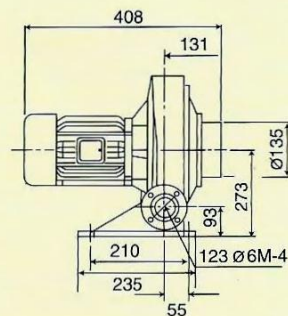
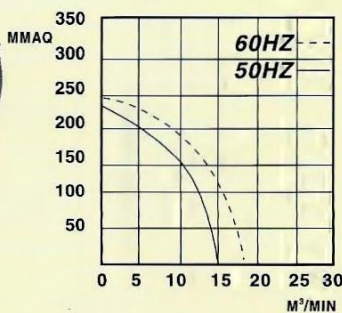

BCT • LF Series

BCT-065 (2.2KW)

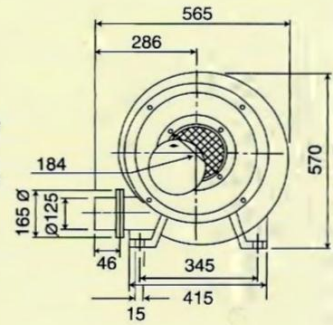
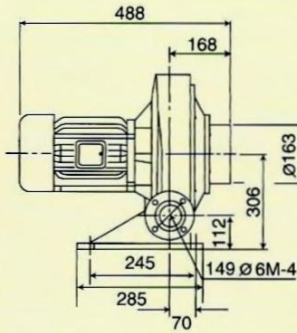
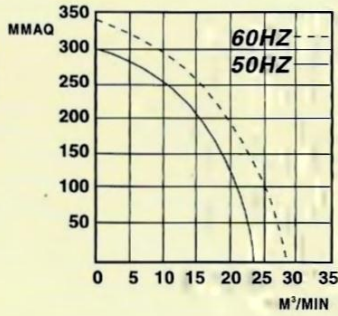

BCT-066 (3.7KW)

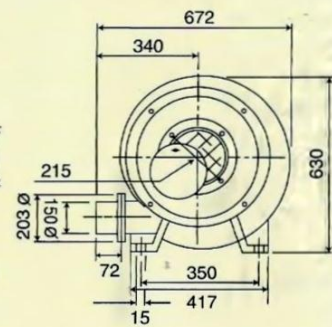
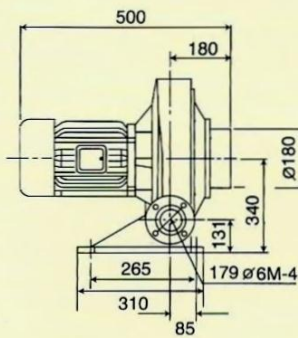
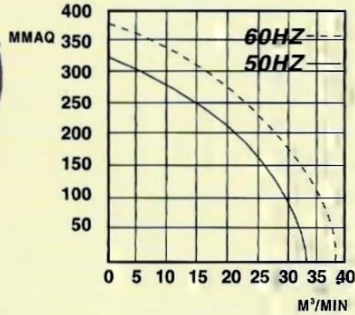

BCT-067-068 (5.5KW)

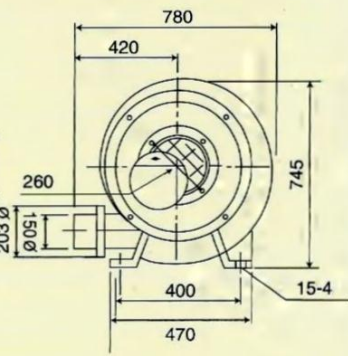
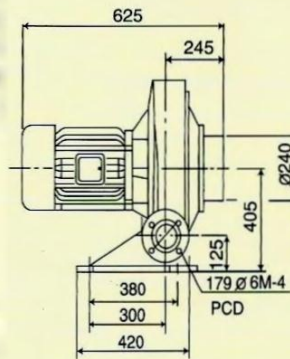
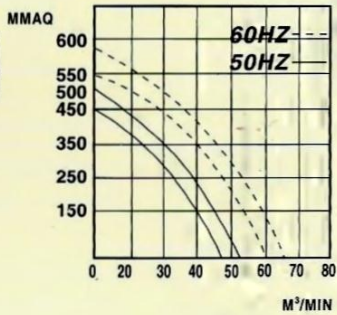

LF-75 (0.1KW)

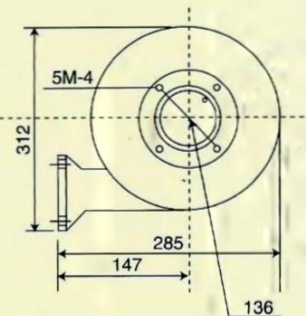
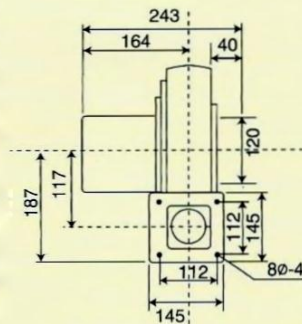
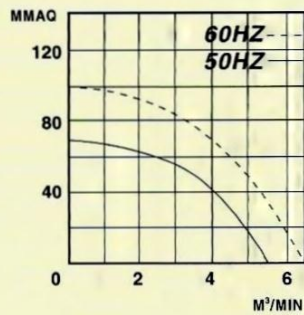

ECO AIR®

We reserve the right to change the design without notice

LF Serial

SIROCCO®

LF-100 (0.2KW)

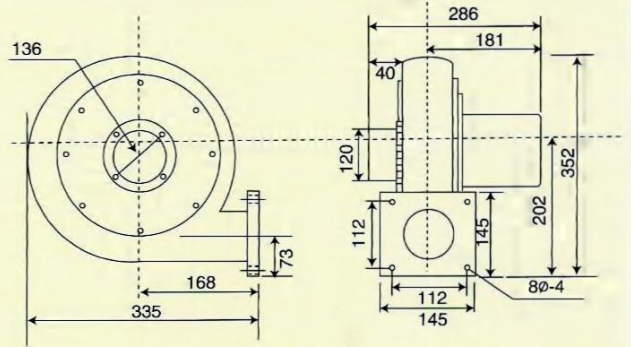
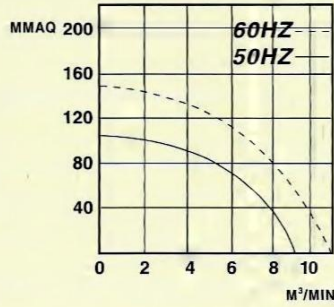

LF-200 (0.2KW)

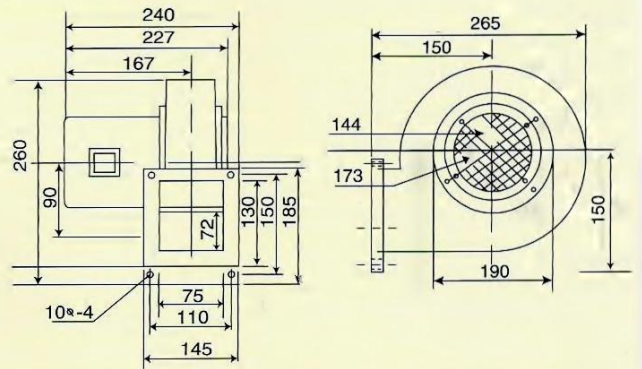
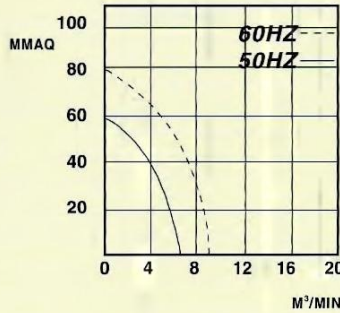

LF-400 (0.4KW)

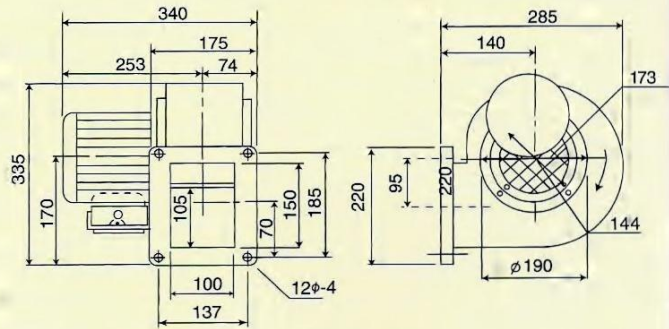
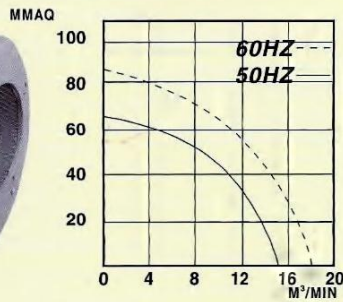

LF-750 (0.75KW)

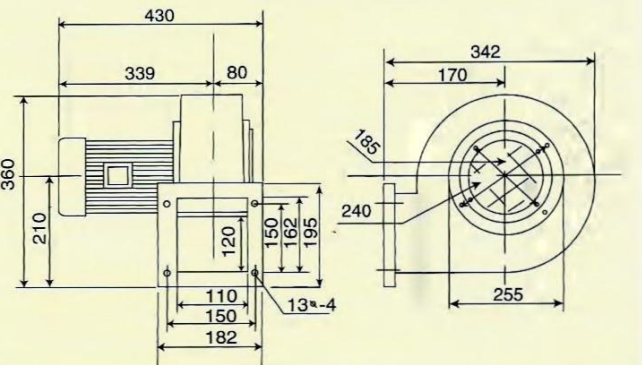
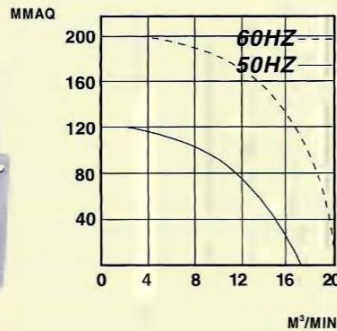

We reserve the right to change the design without notice

YF Series

YF-50 (0.05KW)

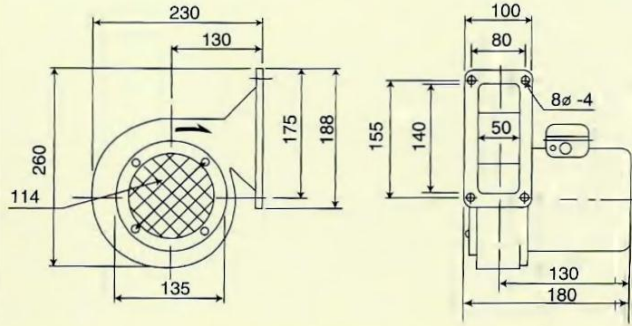
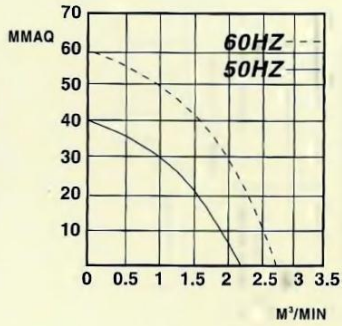

YF-75 (0.1KW)

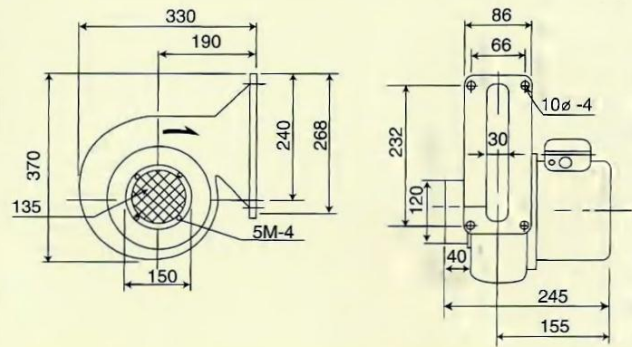
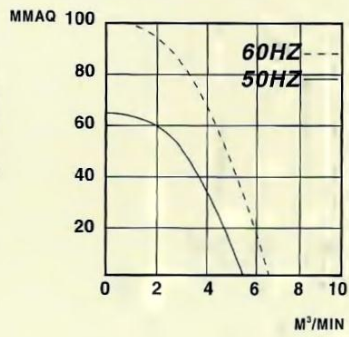

YF-80 (0.05KW)

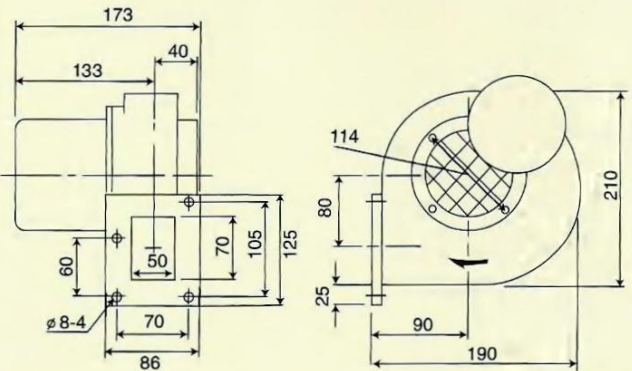
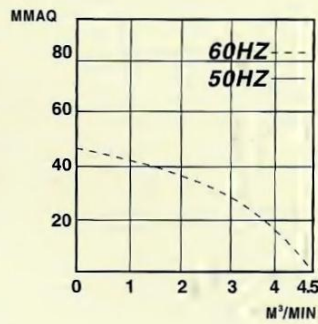

YF-80A (0.05KW)

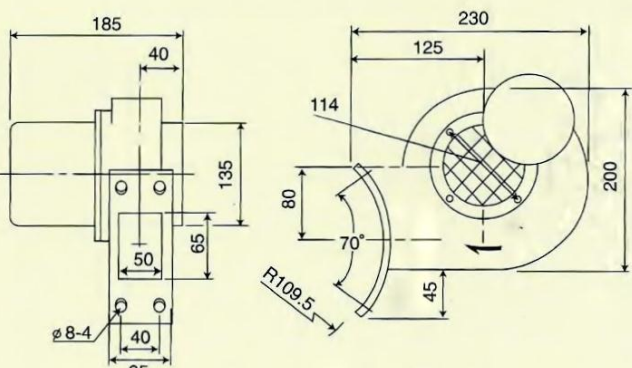
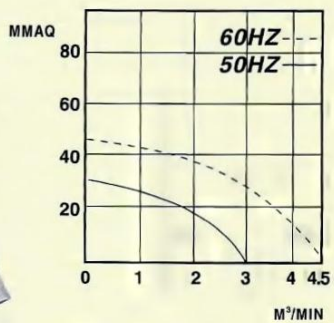

ECO AIR®

We reserve the right to change the design without notice

NT • LS Series

NT-6 (0.4KW)

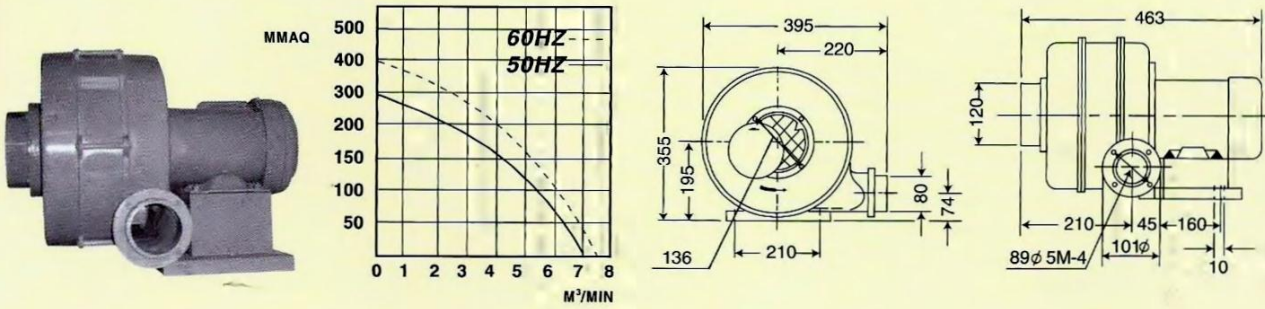

NT-8 (0.75KW)

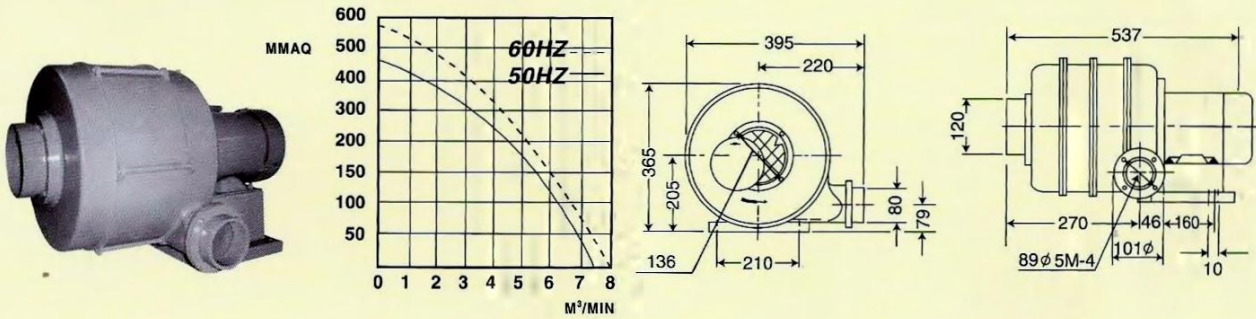

LS-50 (0.05KW)

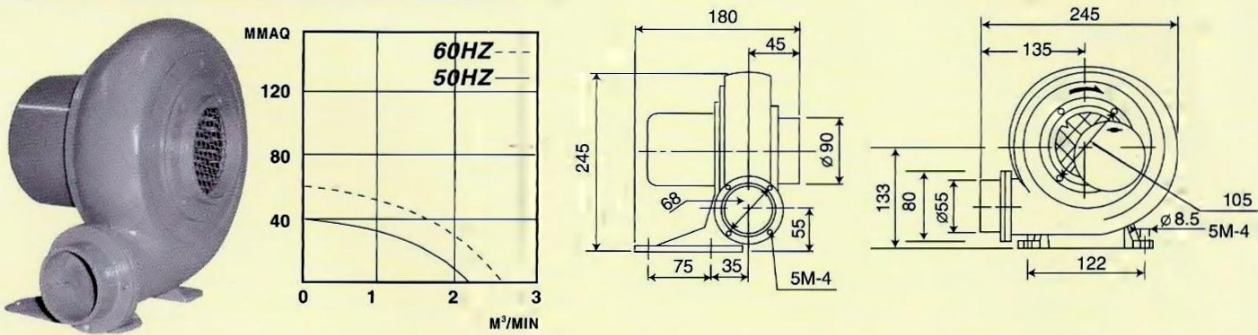

LS-65 (0.08KW)

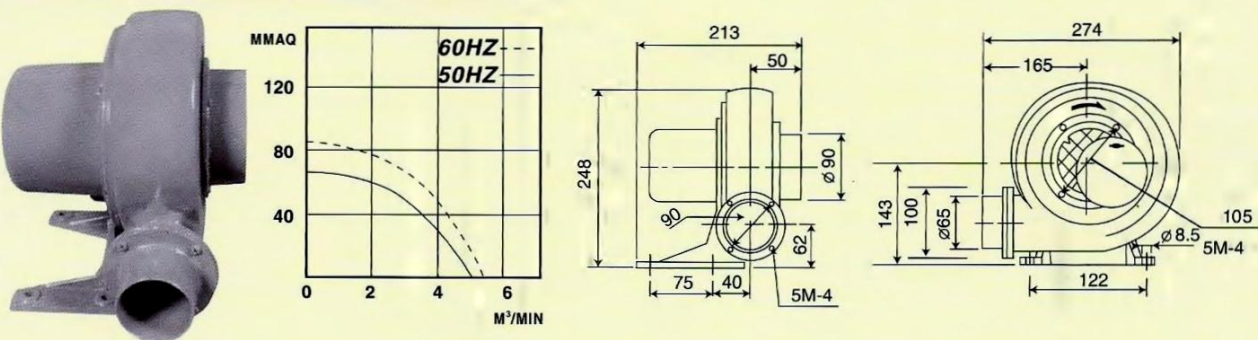

ECO AIR[®]

We reserve the right to change the design without notice

LS • BH-BT Serial

SIROCCO®

LS-75 (0.1KW)

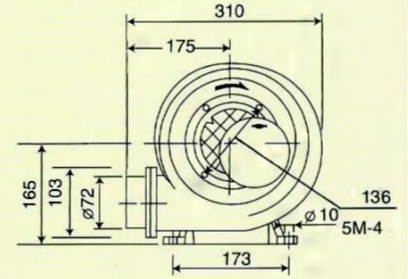
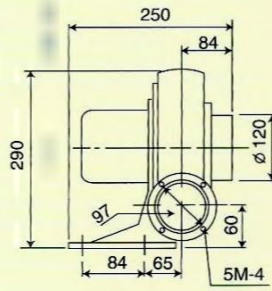
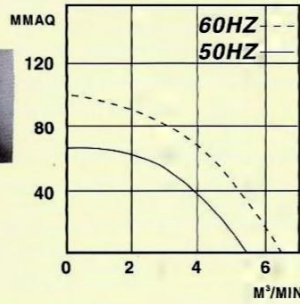

LS-100 (0.2KW)

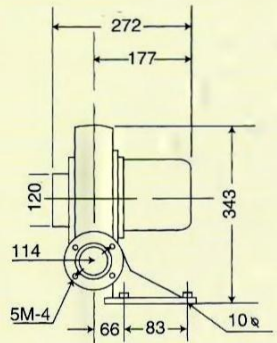
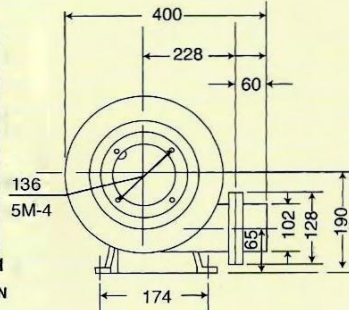
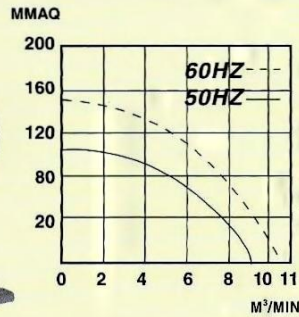

LS-125 (0.4KW)

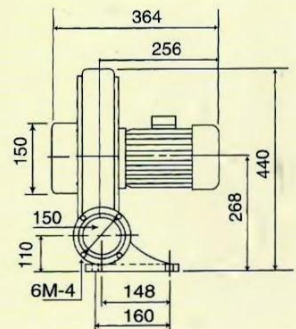
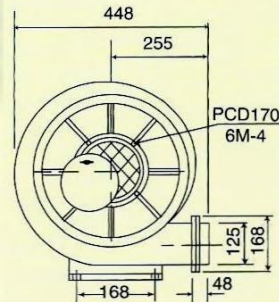
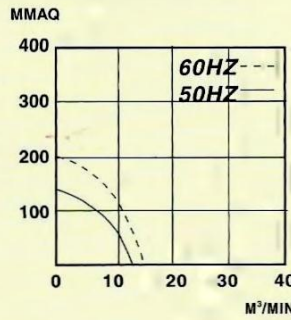
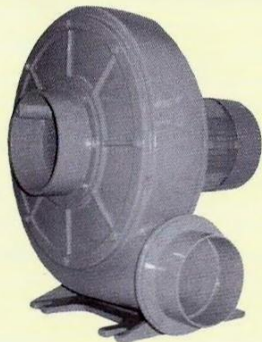

BH-BT (0.05KW)

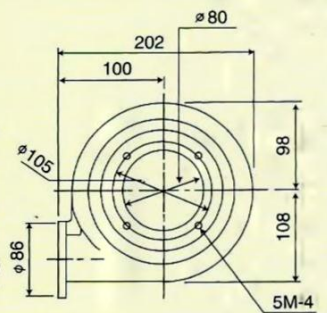
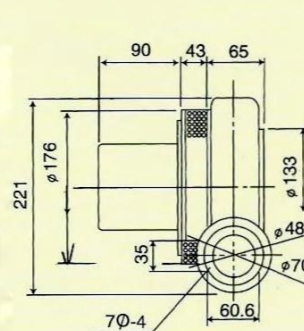
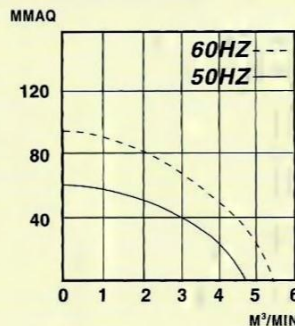

BH-BT Series

BH-1BT (0.08KW)

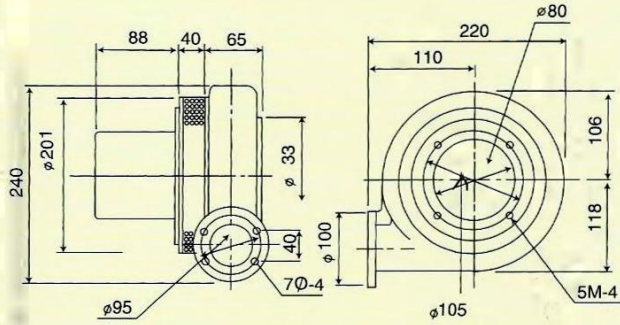
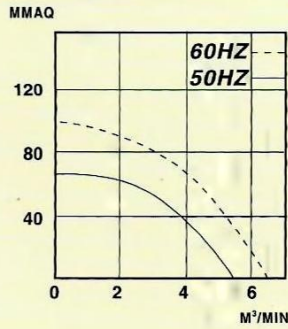

BH-2BT (0.1KW)

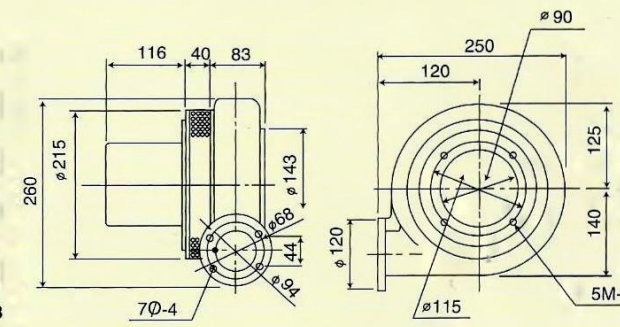
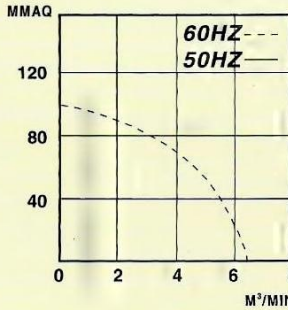

BH-3BT (0.2KW)

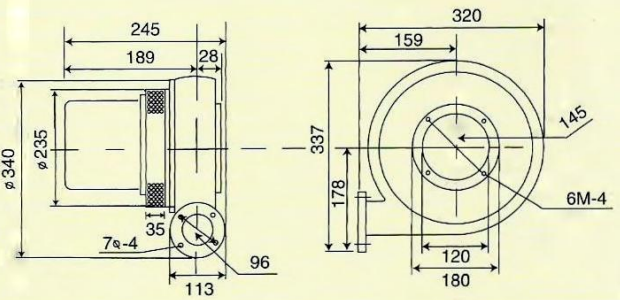
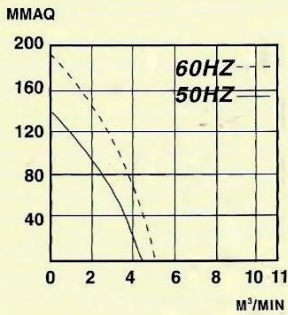

BH-4BT (0.2KW)

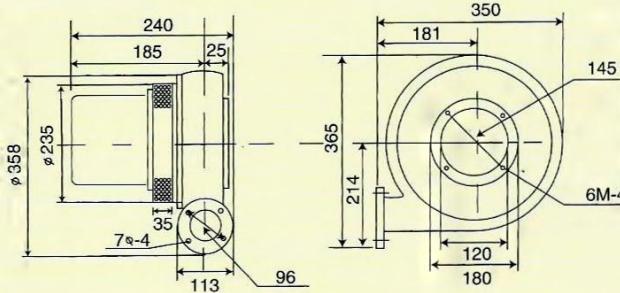
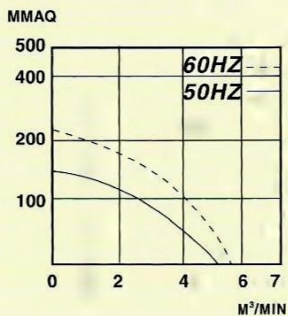

ECO AIR[®]

We reserve the right to change the design without notice

BH-BT • HN-BT Serial

SIROCCO®

BH-5BT (0.4KW)

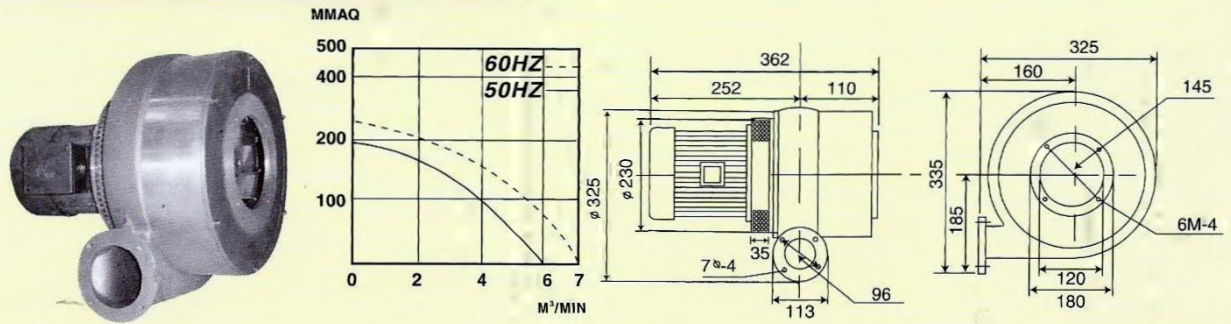

HN-13BT (0.05KW)

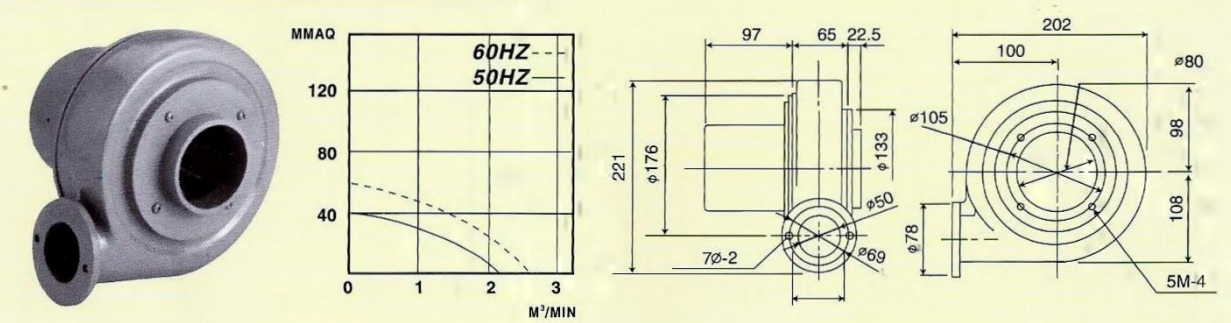

HN-25BT (0.08KW)

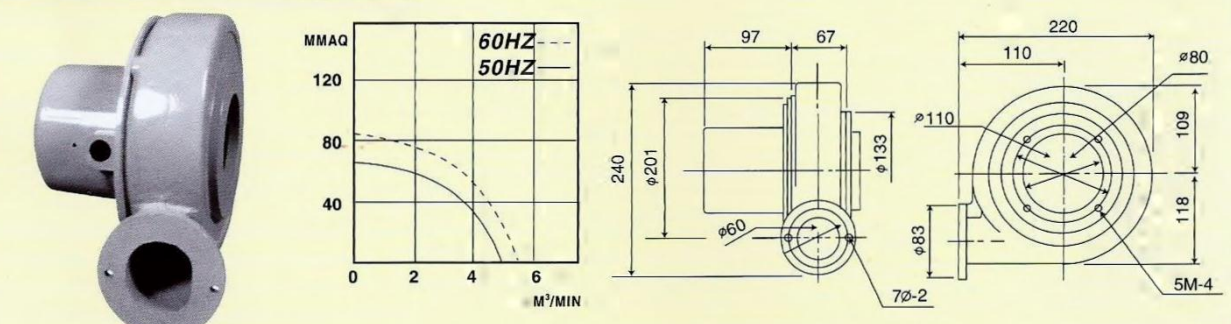

HN-50BT (0.1KW)

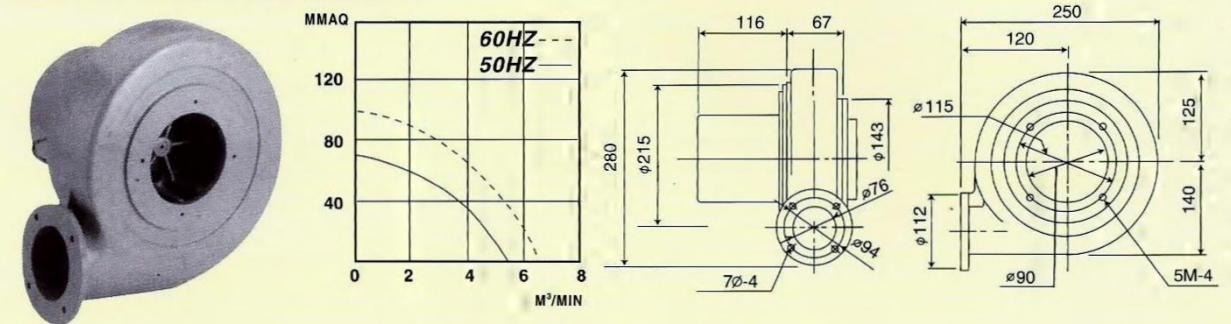

We reserve the right to change the design without notice

New Winstar Enterprise Co., Ltd.

5F-4, No.160 Zhong Zheng Road, Zhonghe District, New Taipei City, Taiwan

Tel: 886-2-22426802 | Fax: 886-2-22424364

E-mail: motor.world@msa.hinet.net | Website: <http://www.ecoair.com.tw>

